



RFS Class I Rocket Assembly Instructions

This is Rocket Science



**Instructions & Photos by:
Great Lakes Space Port Sheboygan Education Foundation, Inc.**



Welcome and thank you for joining the Rockets for Schools Competition

We have developed these expanded instructions for those of you who may not have much modeling experience. If you have any problems during your rocket's construction, feel free to call me with your questions.

Randy Lutz
Co-Director
Rockets for Schools

Daytime Phone — 920.451.3801
Evening Phone — 920.458.6299

Additional Items and Supplies You Will Need

150 Grit & 220 Grit Sandpaper
3/32", 5/32", 3/16" drill Bits and Drill
3/4" Masking Tape
Plastic Gloves
Ruler
Pencil
Primer
Paint

General Assembly Tips (PLEASE READ)

- Before you start building your rocket, familiarize yourself with these instructions and the proper sequence of assembly steps as outlined.
- This rocket is flown with high-impulse rocket motors. For maximum strength and model integrity you must use the supplied epoxy throughout its entire construction unless noted otherwise.
- **IMPORTANT:** Before epoxying any parts to the phenolic tubing, make sure you rough it up by sanding the mating surfaces with 150 grit sandpaper to create a better bond.
- Test fit all components prior to bonding them together with epoxy. Some components may require light sanding to ensure a proper fit.

Step #1

Parts Identification

1.1 Layout all the parts from the kit and identify them with the parts list below

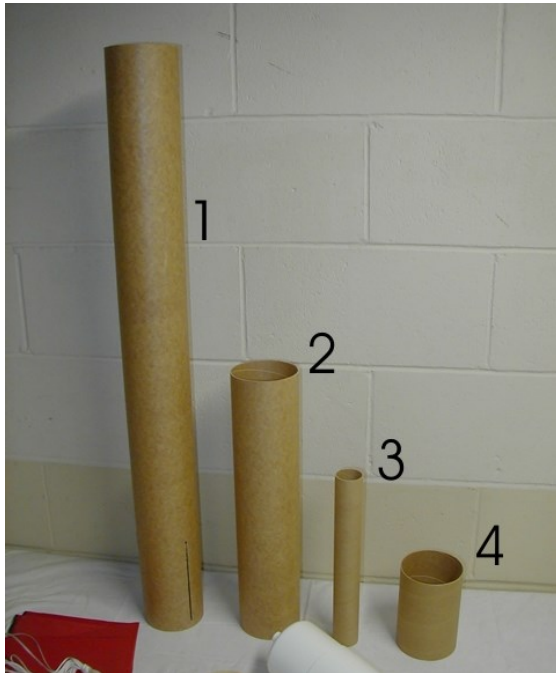

ID No.	Quant.	Description
1	1	36" length / 4" diameter Pre-slotted Booster Tube
2	1	18" length / 4" diameter Payload Tube
3	1	12" length / 38mm dia. Motor Tube
4	1	6" length payload coupler
5	1	Plastic Nose Cone
6	3	.093" G-10 Fiberglass Fins
7	1	Payload Bulkhead
8	1	Forward Centering Ring
9	1	Aft Centering Ring
10	1	28" Round Nylon Parachute
11	1	5/8" Wide Tubular Nylon Cord
12	1	Bag Hardware
Not Shown:	1	5 Minute Epoxy

Step #2

Assembly of the Motor Tube



2.1 Take the Aft centering ring and insert the 1/4" T-nut in the hole as shown. Use a hammer to pound the T-nut flush with the front of the centering ring. The flange of the T-nut may not sit flush on the centering ring. Dab some epoxy on the T-nut flanges to ensure they do not back out of the holes.

Do not get epoxy in the threaded holes of the T-nut.

2.2 Mount an eyebolt through the 1/4" hole in the Forward Centering Ring. Install a nut / small washer on the top side of the centering ring and a small washer / nut on the bottom. Tighten the nuts and secure both nuts with a drop of epoxy.

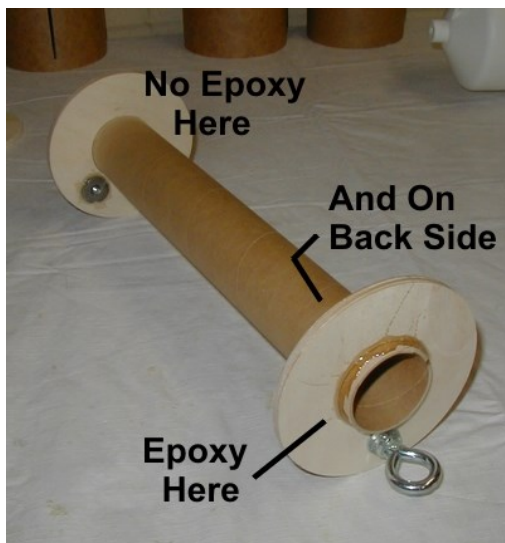

2.3 Test fit the centering rings onto the motor tube. Sand as necessary to insure a secure fit. Position the forward centering ring 1/4 inch from the end of the motor tube. Apply a fillet of epoxy on both sides of the forward centering ring where it meets the motor tube. **Do not epoxy the Aft centering ring at this time!** Set the Motor tube aside to let the epoxy cure.

2.4 Attach the 25 ft. shock cord to the Forward Centering Ring by passing the loop at one end of the shock cord through the eye-bolt in the Front Centering Ring. Now pass the rest of the shock cord through the loop and pull snug. Place a little epoxy on the knot to secure it.



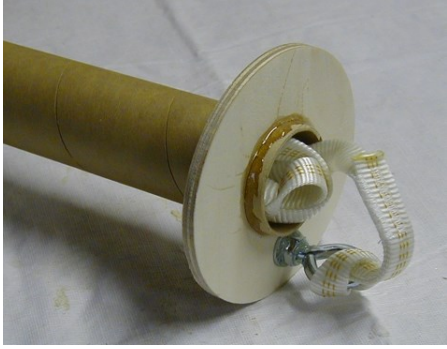

2.5 Now place the shock cord into the motor tube to keep it out of the way for the next step.

Step #3

Mounting the Motor Tube in the Airframe

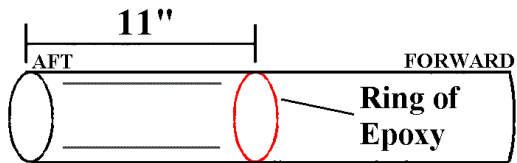

3.1 Start out by mixing up some epoxy. Using a stick or similar item apply a ring of epoxy 11" from the AFT end of the Booster Tube. The aft end of the tube contains the slots for the fins to be added later.

3.2 Position the Forward Centering Ring into the AFT end of the Booster Tube.

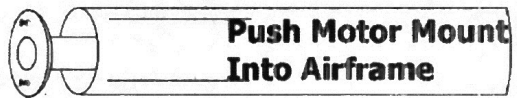

3.3 You can now slide the motor mount assembly up the airframe.



3.4 Double-check that the motor tube is flush with the AFT end of the airframe. **Do NOT epoxy the AFT centering at this time!** Stand the airframe upright and allow the epoxy to cure.

Step #4

Attaching the Fins

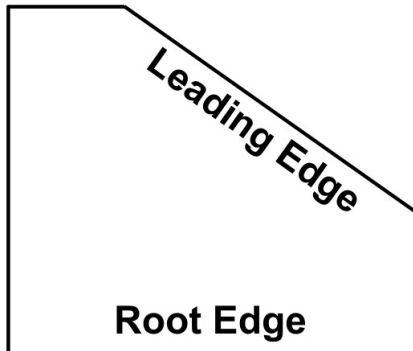

4.1 Apply an epoxy bead to the root edge of the fin.

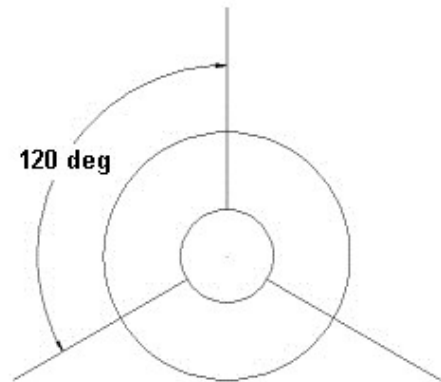

4.2 Push the root edge of the fin through the slot in the airframe onto the motor tube. Make sure the fin is perpendicular to the airframe as shown.



4.3 Use masking tape to hold the fin in position while the epoxy cures. Repeat this process for all fins. Allow the epoxy to fully cure before proceeding to the next step.

4.4 Apply an epoxy fillet to both sides of each fin where the fin meets the exterior part of the airframe. Put on a pair of plastic or rubber gloves. Dip your finger in rubbing alcohol and carefully smooth each epoxy fillet with your finger before it starts to cure. Allow the epoxy to fully cure before rotating the rocket to do the next set of fillets. When the epoxy is fully cured sand with 220 grit sand paper. This gives better adhesion when the primer is applied.

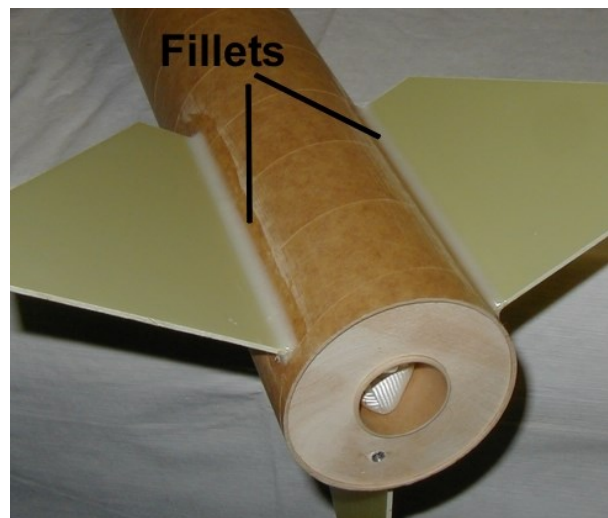

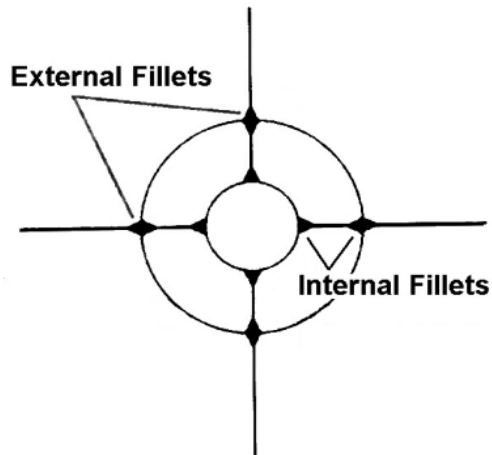

4.5 Screw the 1/4" motor retainer bolt into the T-nut and pull off the aft centering ring. Using a stick or similar item apply an internal epoxy fillet to the root edge of every fin. Allow the epoxy to fully cure before rotating the rocket to do the next set of fillets.

It's very important that this step is done correctly. If the fins are not attached securely, your rocket will not pass the safety check. When all the fillets are complete, you should be able to flex the end of each fin back and forth without breaking them loose from the motor tube.

Step #5

Installing the Rail Buttons

5.1 For additional safety at launch, we are now using rail buttons instead of launch lugs. **Note: You must tape off the rail buttons when you paint your rocket - any paint on the rail buttons may interfere with their operation.**

5.2 Place a ruler against the aft end of the rocket as shown. Mark a spot half way between the two fins.

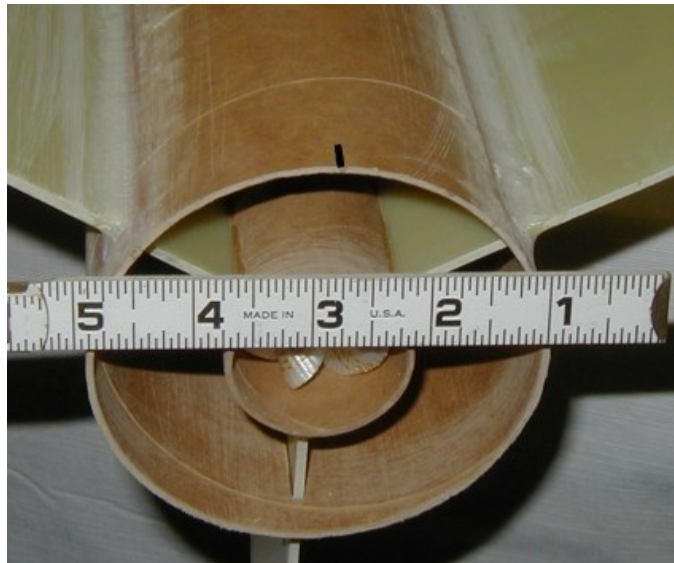

5.3 Using a straight edge (a yard stick works well) site down the body tube and draw a line parallel to the center axis of the tube.

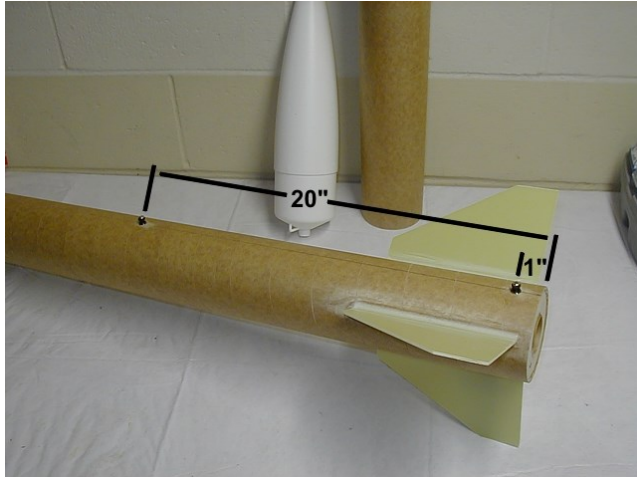

5.4 Drill a $5/32$ " hole 1" and 20" from the Aft end of the body tube along the center line.

5.5 Screw the rail buttons into the two holes using the #8 - $1/2$ " screws. Install the #8 nut on the screw to secure it.

Caution: Do not over-tighten the nut. This may deform the rail button.

5.6 Place a drop of epoxy on each of the nuts to lock them in place. After the epoxy hardens, place a piece of duct tape on the inside of the tube over the upper nut to prevent the parachute from snagging on it.



Step #6

Epoxying the AFT Centering Ring

6.1 You can now epoxy the AFT centering in place. Place a ring of epoxy just inside the Aft end of the booster tube. Install the AFT Centering Ring so it is recessed approximately $1/8$ " into the airframe. Apply a generous epoxy fillet where the motor tube meets the centering ring and where the centering ring meets the airframe. Allow to cure.

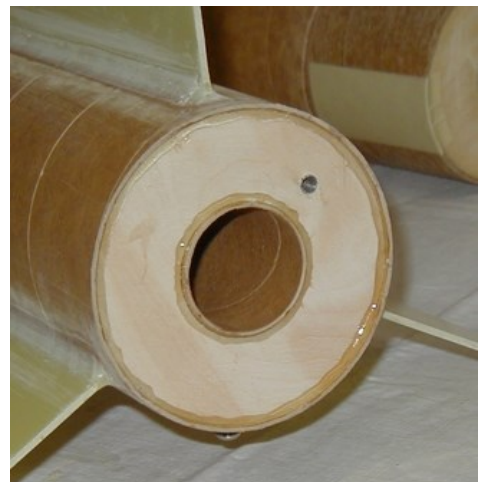

Step #7

Assembling the Payload Section

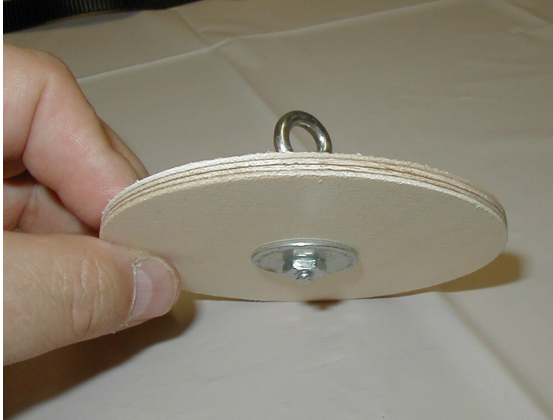

7.1 Start by test fitting the Payload Bulkhead into the 6" long payload coupler. Sand as necessary to ensure a proper fit. Put one nut and large washer on the eyebolt, thread the eyebolt through the hole. On the other side put on a large washer, thread the nut and then tighten. You may want to epoxy the nut in place to lock it in place.



7.2 Recess the bulkhead 1/8" into the 6" long payload coupler. Epoxy the aft side of bulkhead in place using stick or similar item. Once cured, epoxy forward side using a straw or similar item.



7.3 Measure and make a mark in the middle on the coupler. Smear a 2 inch band of epoxy just inside the AFT end of payload tube. Slide coupler into payload section up to the mark. Allow to cure.

Step #8

Finishing Up



8.1 Now would be a good time to attach the nose cone using the sheet metal screws provided. Make three evenly spaced marks 1.5" down from FORWARD end of payload section. Insert the nose cone into the payload section tube and drill three 3/32" holes. Install the sheet metal screws through the payload tube and nose cone to secure it in place.

8.2 Mark a spot 4 1/2 inches down from the forward end of the booster tube. Drill a 3/16" hole at this point.

As the rocket rises in the atmosphere, the air pressure around the rockets drops. This hole bleeds off the higher pressure air in the booster tube to prevent the payload section from "popping off" due to a pressure buildup.



Step #9

Attaching the Recovery System

9.1 Tie an overhand loop knot 8 feet from the free end of the shock cord. See example below.

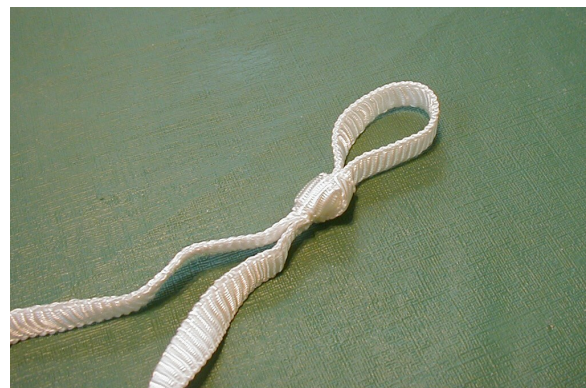
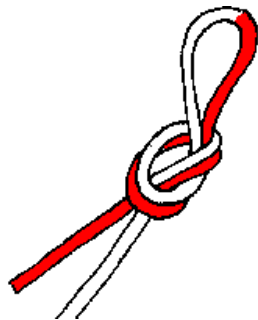



9.2 Lay the parachute flat. Pick up the shroud line loops on at a time and drape them over your hand.

9.2 Grasp the parachute at the apex (the center of the chute) and pull the shroud lines taut.



9.3 Pass the shroud lines through the loop in the white Tubular Nylon Cord. Then pass the parachute through the shroud lines and pull taut.

Note: Put a small amount of epoxy on all the knots to ensure they do not unravel.

Congratulations!



This completes the assembly of your Class I rocket!

Step #10

Finishing

Use the following steps to finish your rocket

- 10.1** Let's start using 150 grit sandpaper to sand the leading edges of the fins (refer to the picture in Step #4 to determine the leading edge), tapering them to a point.
- 10.2** Lightly sand the airframe and cone with a fine sandpaper to allow better adhesion of the primer.
- 10.3 Important - Cover the two rail buttons with masking tape before painting your rocket. Any paint on the rail buttons may interfere with their operation.**
- 10.4** Prime the rocket using primer of choice, following the instructions of the primer.
- 10.5** Fill any imperfections with Bondo or spot putty. Allow to dry and sand again.
- 10.6** Using a tack cloth or rubbing alcohol wipe down entire rocket to remove dust or any other dirt.
- 10.7** Prime the rocket again and when dry, lightly sand with fine sandpaper.
- 10.8** Paint the kit using your choice or spray paint, Krylon is the choice of the manufacturer. This is obviously a fictional kit, so there is no "correct" paint scheme. Let your imagination run wild!!
- 10.8** Once paint is applied and fully dry, clear coat the rocket using clear coat of choice. This seals the rocket and helps keep water from penetrating.